

DO NOT SCALE FROM THIS PRINT

FIG. 1
IPD1-06-D SHOWN

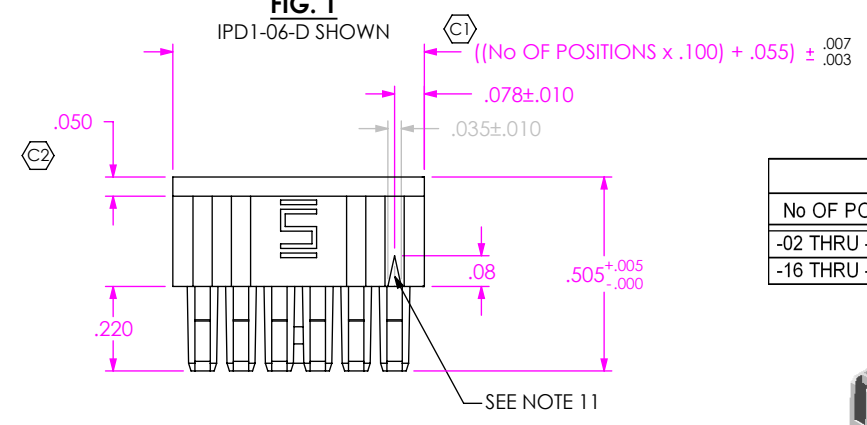
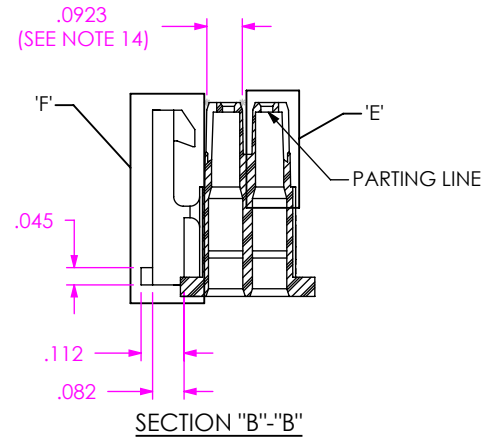
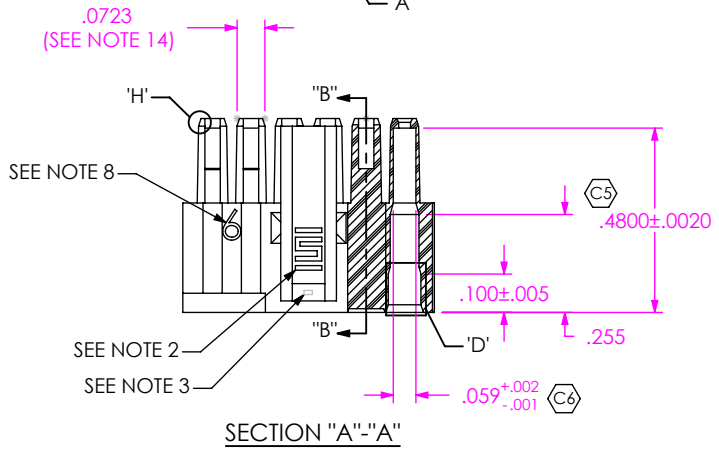
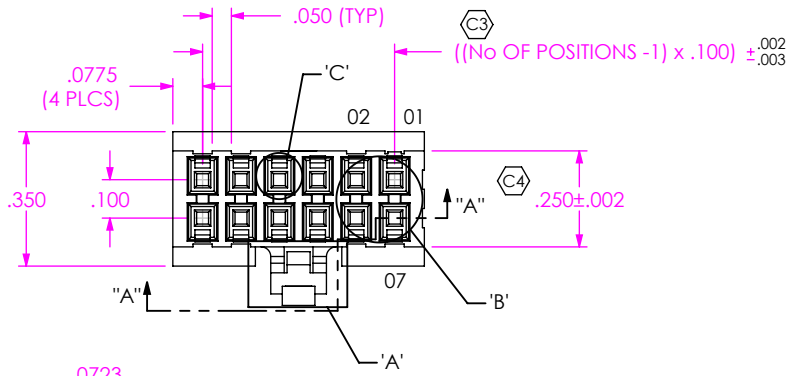
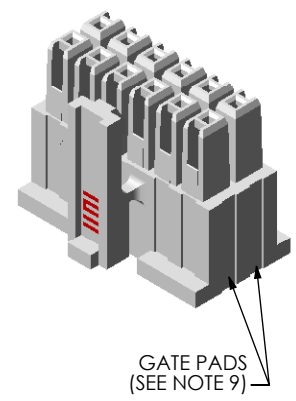

TABLE 1

No OF POS	T/B BOW	S/S BOW
-02 THRU -15	.002	.002
-16 THRU -25	.003	.003



IPD1-XX-D-X

No OF POSITIONS
-02 THRU -25
(PER ROW)
[SEE FIG. 2 FOR -02 POSITION]

POLARIZATION OPTION
-P: POLARIZED
(NOT AVAILABLE WITH
-K OPTION)
(LEAVE BLANK FOR
NO POLARIZATION)
(SEE FIG. 3)
G *-K: KEYED POLARIZATION
(NOT AVAILABLE WITH
-P OPTION)
(SEE SHEET 2, FIG. 4)

*NOT RELEASED FOR PRODUCTION

NOTES:

- ① REPRESENTS A CRITICAL DIMENSION.
- SAMTEC LOGO SHALL APPEAR AT ONE LOCATION ON SURFACE SHOWN, APPROXIMATELY .150 x .094 (BOTH SIDES).
- ALL MULTIPLE CAVITY MOLDS SHALL IDENTIFY EACH CAVITY WITH A LETTER DESIGNATION LOCATED WHERE SHOWN.
- ALL IDENTIFICATION MARKS MUST NOT STAND GREATER THAN .002 OFF THE SURFACE OF THE PART.
- MOLDED SURFACES SHALL BE CONSISTENT AND SMOOTH. SURFACES TO BE FREE OF SCATCHES, NICKS, SINK AREAS, VOIDS OR OTHER BLEMISHES.
- MAX ALLOWABLE BOW: SEE TABLE 1. BOW TO BE MEASURED AT MIDDLE OF PART.
- PART TO BE SYMMETRIC ABOUT THE CENTERLINE WITHIN +/- .002, UNLESS OTHERWISE STATED.
- NUMBER OF POSITIONS (PER ROW) TO BE SHOWN IN THIS AREA EXCLUDING 2, 3 AND 4 POSITIONS. SIZE AND DEPTH SIMILAR TO POSITION 1 INDICATOR.
- GATE PADS MUST BE RECESSED .005.
- END CORES ARE POLARIZED. CONFIRM GEOMETRY RELATIVE TO POSITION 1 INDICATOR & GATE PADS.
- G POSITION 1 INDICATOR TO BE RAISED .005 MAX, NOT PRESENT ON 2 POSITION OPTION.
- SPECIFIED POSITIONS TO BE IDENTIFIED WHERE SHOWN (NOTE 4 APPLIES).
- MOLD DESIGNER HAS DISCRETION OVER RIB LOCATION. STEEL PRINT SETUP SHEET MUST SHOW RIB CONFIGURATION FOR EACH PART NUMBER.
- PART MUST DRAFT INWARD FROM BOTTOM TO TOP OF STACK.
- ALL DIMENSIONS TO BE SYMMETRIC ABOUT CENTERLINE WITHIN .0015 UNLESS OTHERWISE STATED.

ROW SPECIFICATION
-D: DOUBLE

FIG. 3
IPD1-06-D-P SHOWN
(SAME AS FIG. 1, EXCEPT AS SHOWN)

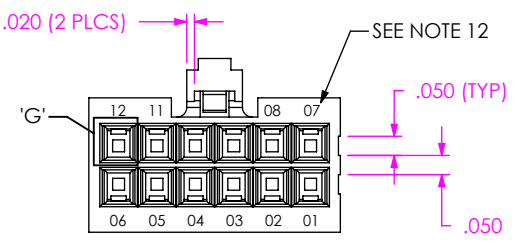
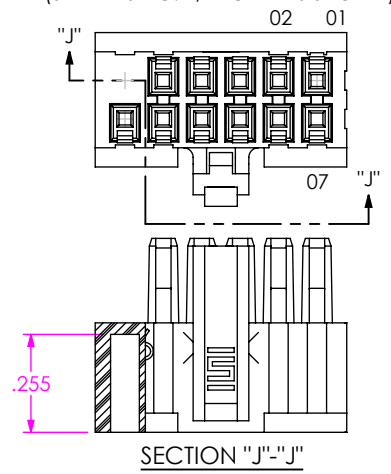

UNLESS OTHERWISE SPECIFIED, DIMENSIONS ARE IN INCHES.
TOLERANCES ARE:
DECIMALS ANGLES
.XX: ±.01 [.3]
.XXX: ±.003 [.08]
.XXXX: ±.0015 [.038]

PROPRIETARY NOTE
THIS DOCUMENT CONTAINS INFORMATION CONFIDENTIAL AND PROPRIETARY TO SAMTEC, INC. AND SHALL NOT BE REPRODUCED OR TRANSFERRED TO OTHER DOCUMENTS OR DISCLOSED TO OTHERS OR USED FOR ANY PURPOSE OTHER THAN THAT WHICH IT WAS OBTAINED WITHOUT THE EXPRESSED WRITTEN CONSENT OF SAMTEC, INC.

MATERIAL: DO NOT SCALE DRAWING SHEET SCALE: 2:1
ZYTEL 103FHS, COLOR: WHITE

MAX REGRIND: 25%
MAX FLASH ALLOWED: .004
MAX GATE VESTIGE: .002

c:\enterprise\ault\DWG\MISC\MKTG\IPD1-XX-D-X-MKT.SLDDRW

520 PARK EAST BLVD., NEW ALBANY, IN 47150
PHONE: 812-944-6733 FAX: 812-948-5047
e-Mail: info@SAMTEC.com code: 53322

DESCRIPTION: .100 SHROUDED CONTACT BODY

DWG. NO. IPD1-XX-D-X

BY: CHAD F 03/05/2002 SHEET 1 OF 2

REVISION G

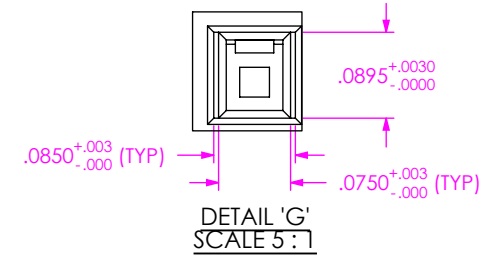
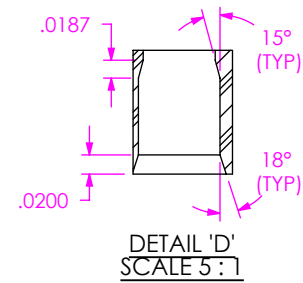
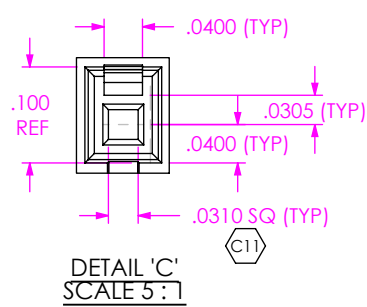
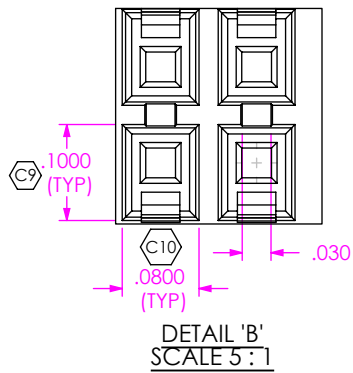
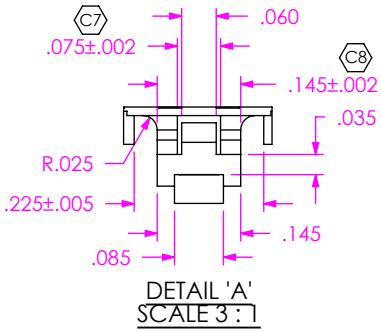

FIG. 2
-02 POSITION
(SAME AS FIG. 1, UNLESS OTHERWISE STATED)

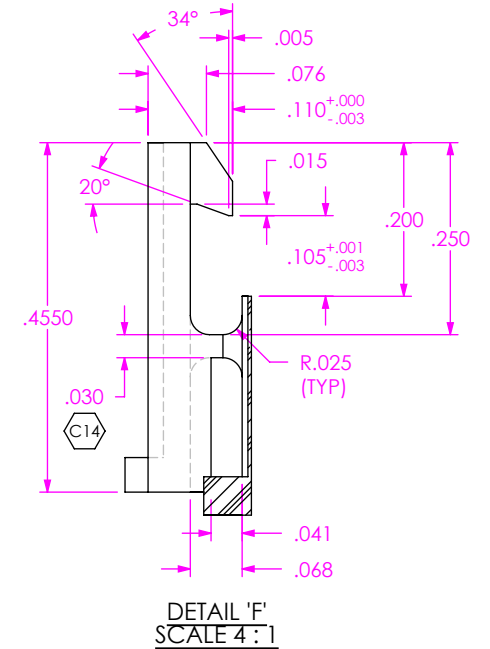
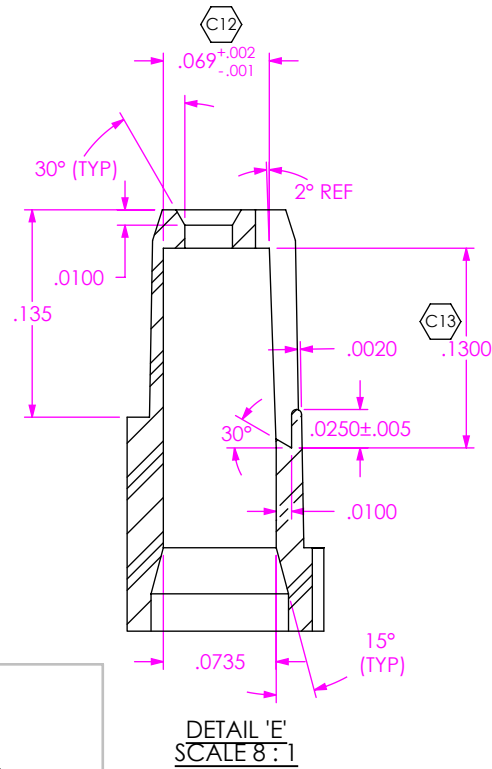
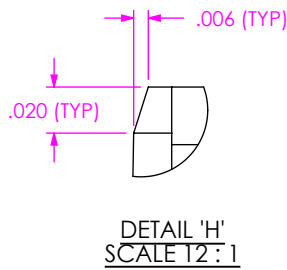
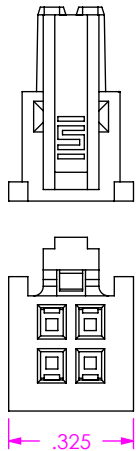
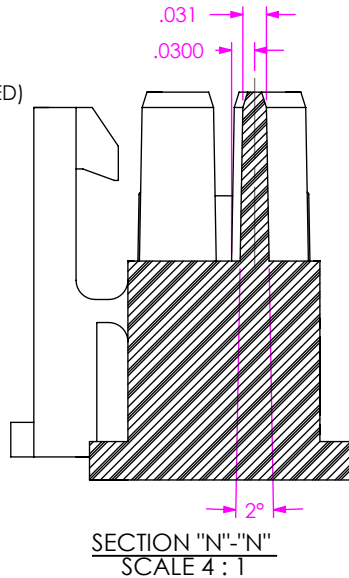
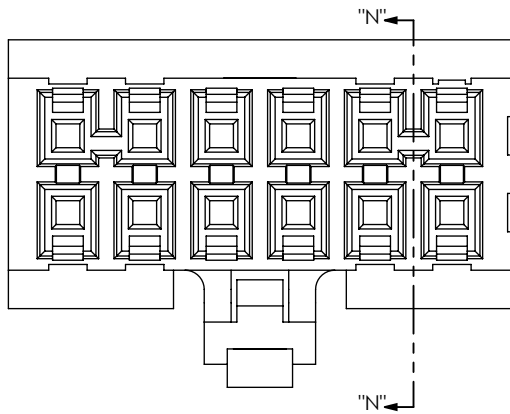

FIG. 4
-K: KEYED POLARIZATION
(IPD1-06-D-K SHOWN)
(SAME AS FIG. 1, UNLESS OTHERWISE STATED)

NOT RELEASED FOR PRODUCTION



PROPRIETARY NOTE
THIS DOCUMENT CONTAINS INFORMATION
CONFIDENTIAL AND PROPRIETARY TO
SAMTEC, INC. AND SHALL NOT BE REPRODUCED
OR TRANSFERRED TO OTHER DOCUMENTS OR
DISCLOSED TO OTHERS OR USED FOR ANY
PURPOSE OTHER THAN THAT WHICH IT WAS
OBTAINED WITHOUT THE EXPRESSED WRITTEN
CONSENT OF SAMTEC, INC.

DO NOT SCALE DRAWING
SHEET SCALE: 2:1

c:\enterprise\ault\DWG\MISC\MKTG\IPD1-XX-D-X-MKT.SLDDRW

samtec

520 PARK EAST BLVD, NEW ALBANY, IN 47150
PHONE: 812-944-6733 FAX: 812-948-5047
e-Mail: info@SAMTEC.com code: 55322

DESCRIPTION: .100 SHROUDED CONTACT BODY

DWG. NO. IPD1-XX-D-X

BY: CHAD F 03/05/2002 SHEET 2 OF 2